

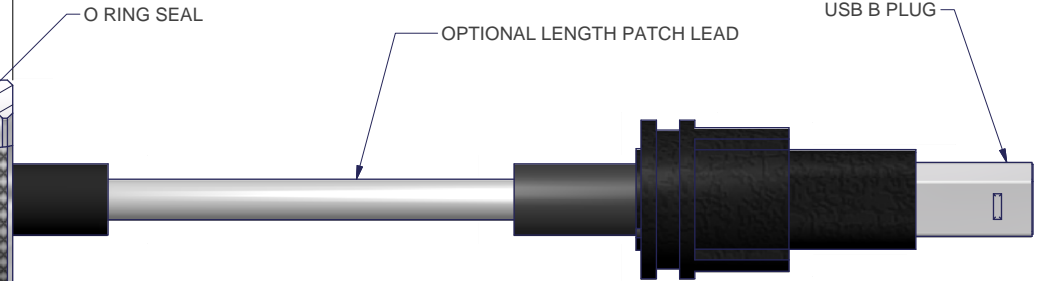

3RD ANGLE PROJECTION

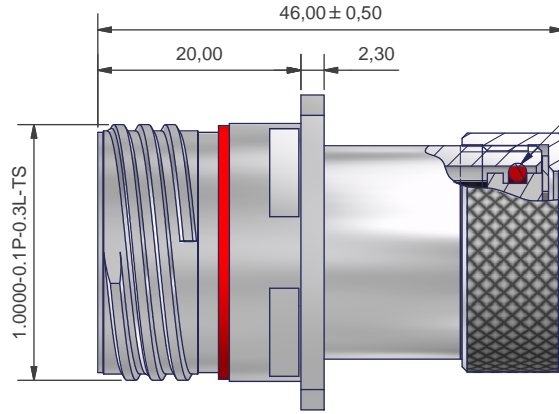

REMOVE ALL SHARP EDGES AND BURRS

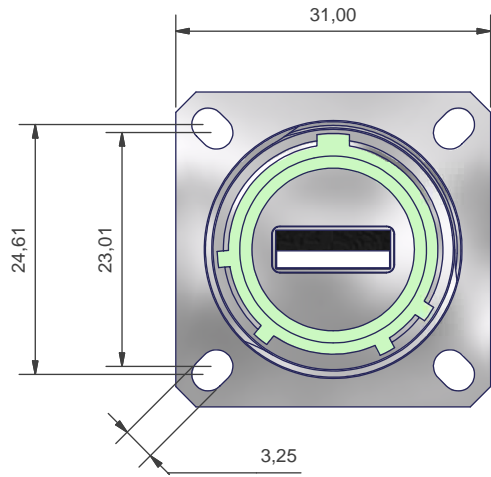

**NOTES**  
 GENERALLY TO THE REQUIREMENTS OF MIL-DTL-38999  
 FINISH  
 SEE TABLE  
 MATERIALS  
 USB B INSERT  
 CONTACTS 30µ Au/Ni  
 SHIELDING - NICKEL PLATED BRASS  
 BODY - PA, UL94V-0  
 PCB - FR4, UL94V-0

**SHELL OPTIONS**  
 1 = ALUM ALLOY 6262R  
 2 = ALUM BRONZE NES833  
 4 = STAINLESS STEEL 303  
 46 = STAINLESS STEEL 316

SEAL - FLOURO SILICONE  
 INSULATOR - PPS GL40 UL94  
 POTTING - QSIL 550 UL94V-0  
**PERFORMANCE**  
 CURRENT RATING 1 AMP MAX PER CONTACT  
 VOLTAGE RATING 30V AC  
 TEMPERATURE -25°C TO +85°C

CODE	DESCRIPTION
B	Cadmium, olive drab (5-10 microns) QQ-P-416, Type II, Class 3 over electroless nickel (2.5 - 7.5 microns) (500 hour salt spray finish)
C	Electroless Nickel, MIL-C-26074, Class 4, Grade B
J	Passivate, per QQ-P-35 or MI-S-5002
P	Heavy Nickel, 500 hour salt spray
Z	Shot blast for non-reflective finish
ZB	Zinc cobalt, olive drab (5-10 microns) over electroless nickel (2.5 - 7.5 microns)

ORDERS CANNOT BE PLACED AGAINST ALPHA ISSUE DRAWINGS.  
 ON RECEIPT OF CUSTOMER APPROVAL, THE DRAWING STATUS WILL RAISE TO ISSUE 1.

**PC4B0027-15N-1-C-L2000**

SERIES \_\_\_\_\_  
 SHELL SIZE \_\_\_\_\_  
 ALTERNATE KEYING (N, A, B, C, D, E) \_\_\_\_\_  
 MATERIAL \_\_\_\_\_  
 PLATING \_\_\_\_\_  
 CABLE LENGTH, OPTIONS 1, 2, 3, 5 METRE \_\_\_\_\_

ISSUE	DCR NO.	DATE	APPROVED	MATERIAL	UNLESS OTHERWISE SPECIFIED ALL DIMENSIONS IN MILLIMETRES TOLERANCE ON DIMENSIONS +/-0.1MM TOLERANCE ON ANGLES +/- 1 DEGREE	DO NOT SCALE THIS DRAWING	POLAMCO LTD	WESTON LOCK LOWER BRISTOL ROAD BATH BA2 1EP	PART NO
A		04/01/2010	MP						PC4B0027-15N-1-C-LXXXX
						THIS DRAWING IS COPYRIGHT, AND THE PROPERTY OF POLAMCO LTD. IT MUST NOT BE COPIED, USED FOR MANUFACTURE OR OTHERWISE DISCLOSED WITHOUT PRIOR WRITTEN CONSENT OF THE COMPANY.	TITLE		ASSY USED ON
							USB A CABLED PLUG RECEPTACLE ASSEMBLY		D38999/20 USB A
					WEIGHT				DRAWING NO
					DRAWN	M.PAUL			C1989