

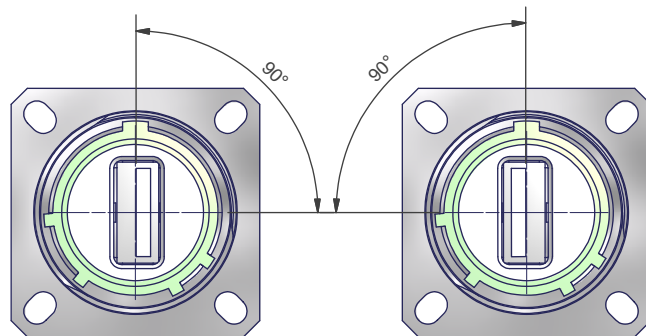

3RD ANGLE PROJECTION

REMOVE ALL SHARP EDGES AND BURRS

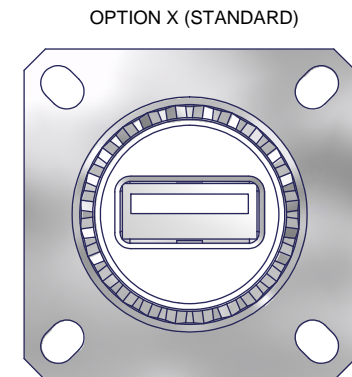
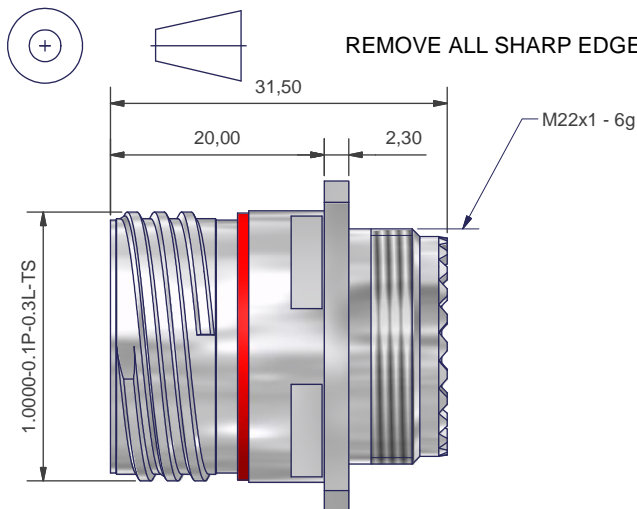
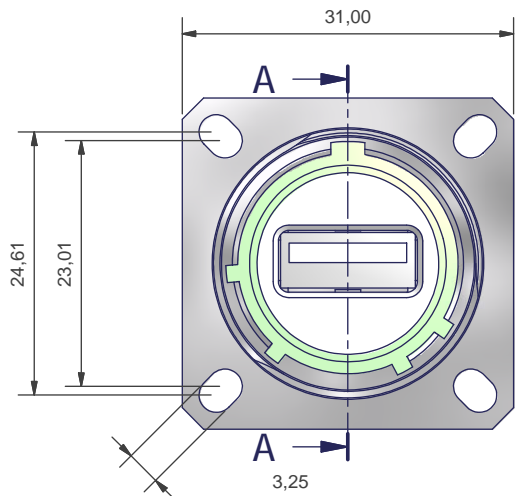

NOTES
 GENERALLY TO THE REQUIREMENTS OF MIL-DTL-38999
 FINISH
 SEE TABLE
 MATERIALS
 USB B INSERT
 CONTACTS 30µ Au/Ni
 SHIELDING - NICKEL PLATED BRASS
 BODY - PA, UL94V-0
 PCB - FR4, UL94V-0

SHELL OPTIONS
 1 = ALUM ALLOY 6262R
 2 = ALUM BRONZE NES833
 4 = STAINLESS STEEL 303
 46 = STAINLESS STEEL 316

SEAL - FLOURO SILICONE
 INSULATOR - PPS GL40 UL94
 POTTING - QSIL 550 UL94V-0
PERFORMANCE
 CURRENT RATING 1 AMP MAX PER CONTACT
 VOLTAGE RATING 30V AC
 TEMPERATURE -25°C TO +85°C

CODE	DESCRIPTION
B	Cadmium, olive drab (5-10 microns) QQ-P-416, Type II, Class 3 over electroless nickel (2.5 - 7.5 microns) (500 hour salt spray finish)
C	Electroless Nickel, MIL-C-26074, Class 4, Grade B
J	Passivate, per QQ-P-35 or MI-S-5002
P	Heavy Nickel, 500 hour salt spray
Z	Shot blast for non-reflective finish
ZB	Zinc cobalt, olive drab (5-10 microns) over electroless nickel (2.5 - 7.5 microns)

PC4B0026-15NZ-1-C

SERIES _____
 SHELL SIZE _____
 ALTERNATE KEYING (N, A, B, C, D, E) _____
 INSERT ROTATION (X = 0°, Y = 90°, Z=270°) _____
 MATERIAL _____
 PLATING _____

ORDERS CANNOT BE PLACED AGAINST ALPHA ISSUE DRAWINGS.
 ON RECEIPT OF CUSTOMER APPROVAL, THE DRAWING STATUS WILL RAISE TO ISSUE 1.

ISSUE	DCR NO.	DATE	APPROVED	MATERIAL	UNLESS OTHERWISE SPECIFIED ALL DIMENSIONS IN MILLIMETRES TOLERANCE ON DIMENSIONS +/-0.1MM TOLERANCE ON ANGLES +/- 1 DEGREE	DO NOT SCALE THIS DRAWING	POLAMCO LTD	WESTON LOCK LOWER BRISTOL ROAD BATH BA2 1EP	PART NO
A		22/10/2009	MP						PC4B0026-15N-1-ZB
									ASSY USED ON
									D38999/20 USB A
									DRAWING NO
									C1907

POLAMCO LTD

TITLE
USB A RECEPTACLE ASSEMBLY

THIS DRAWING IS COPYRIGHT, AND THE PROPERTY OF POLAMCO LTD. IT MUST NOT BE COPIED, USED FOR MANUFACTURE OR OTHERWISE DISCLOSED WITHOUT PRIOR WRITTEN CONSENT OF THE COMPANY.

WEIGHT
DRAWN M.PAUL

DRAWING NO
C1907