

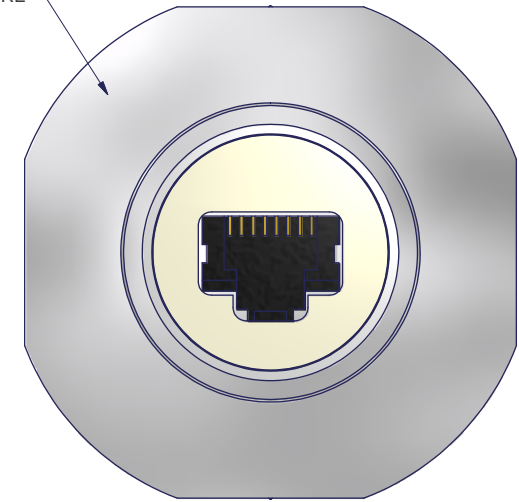

3RD ANGLE PROJECTION

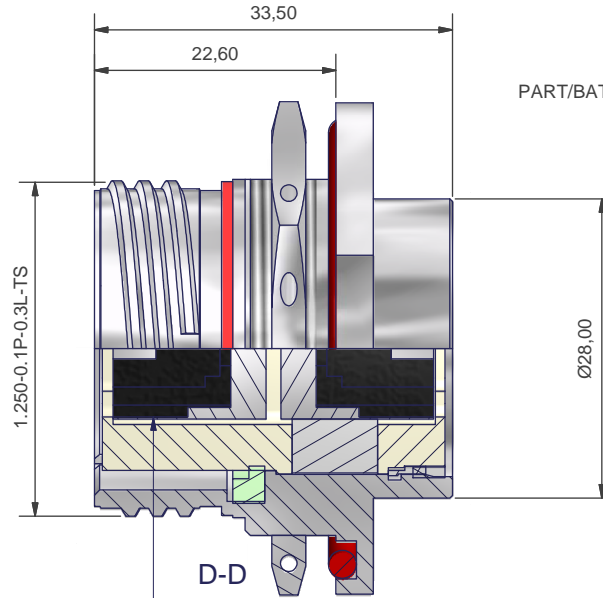

REMOVE ALL SHARP EDGES AND BURRS

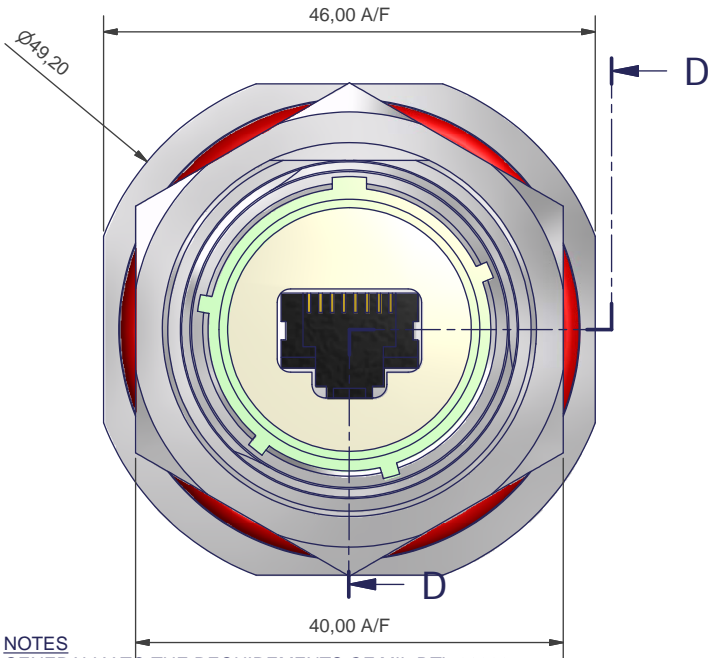

RJ45, CAT6 FEED THRU CONNECTOR GROUNDED TO OUTER SHELL  
UNLESS OPTION 'U' IS SPECIFIED (FEEDTHRU ISOLATED FROM OUTER SHELL)

NOTES  
GENERALLY TO THE REQUIREMENTS OF MIL-DTL-38999

FINISH  
SEE TABLE

MATERIALS  
RJ45  
CONTACTS COPPER WITH SELECTIVE GOLD PLATE  
SHIELDING - NICKEL PLATED BRASS  
BODY - PA, UL94V-0  
PCB - FR4, UL94V-0

SHELL OPTIONS  
1 = ALUM ALLOY 6262R  
2 = ALUM BRONZE NES833  
4 = STAINLESS STEEL 303  
46 = STAINLESS STEEL 316

SEAL - SILICONE ELASTOMER  
INSULATOR - PPS GL40 UL94, COLOUR BLACK  
POTTING - QSIL 550 UL94V-0  
PERFORMANCE  
VOLTAGE RATING 50V DC / 35V AC  
TEMPERATURE -40°C TO +120°C

| PLATING OPTIONS |  |
|-----------------|--|
| CODE            | DESCRIPTION  |
| B               | Cadmium, olive drab (5-10 microns) QQ-P-416, Type II, Class 3 over electroless nickel (2.5 - 7.5 microns) (500 hour salt spray finish) |
| C               | Electroless Nickel, MIL-C-26074, Class 4, Grade B  |
| J               | Passivate, per QQ-P-35 or MI-S-5002  |
| P               | Heavy Nickel, 500 hour salt spray  |
| Z               | Shot blast for non-reflective finish   |
| ZB              | Zinc cobalt, olive drab (5-10 microns) over electroless nickel (2.5 - 7.5 microns)   |

**PC4F0014-19N-1-C-U**

SERIES \_\_\_\_\_  
SHELL SIZE \_\_\_\_\_  
ALTERNATE KEYING \_\_\_\_\_  
MATERIAL \_\_\_\_\_  
PLATING \_\_\_\_\_  
NO GROUNDING OPTION (OMIT FOR STANDARD) \_\_\_\_\_

| ISSUE | DCR NO. | DATE       | APPROVED |
|-------|---------|------------|----------|
| 1     |         | 21/07/2009 | JLM      |
|       |         |            |          |
|       |         |            |          |
|       |         |            |          |

**MATERIAL**

UNLESS OTHERWISE SPECIFIED ALL DIMENSIONS IN MILLIMETRES TOLERANCE ON DIMENSIONS +/-0.1MM TOLERANCE ON ANGLES +/- 1 DEGREE

WEIGHT  
DRAWN M.PAUL

DO NOT SCALE THIS DRAWING

THIS DRAWING IS COPYRIGHT, AND THE PROPERTY OF POLAMCO LTD. IT MUST NOT BE COPIED, USED FOR MANUFACTURE OR OTHERWISE DISCLOSED WITHOUT PRIOR WRITTEN CONSENT OF THE COMPANY.

**POLAMCO LTD**

WESTON LOCK  
LOWER BRISTOL ROAD  
BATH BA2 1EP

TITLE  
**RJ45 FEEDTHRU JAM NUT RECEPTACLE**

PART NO  
**PC4F0014-19N-1-C**  
ASSY USED ON  
**MIL-DTL-38999/24**  
DRAWING NO  
**C1690**