

# 100P275 SERIES

## HEAT SHRINK GLAND KIT



For modifications see page:

➤ Visit our on-line catalogue or contact sales on ➤ [www.polamco.com](http://www.polamco.com) ➤ [sales@polamco.co.uk](mailto:sales@polamco.co.uk)

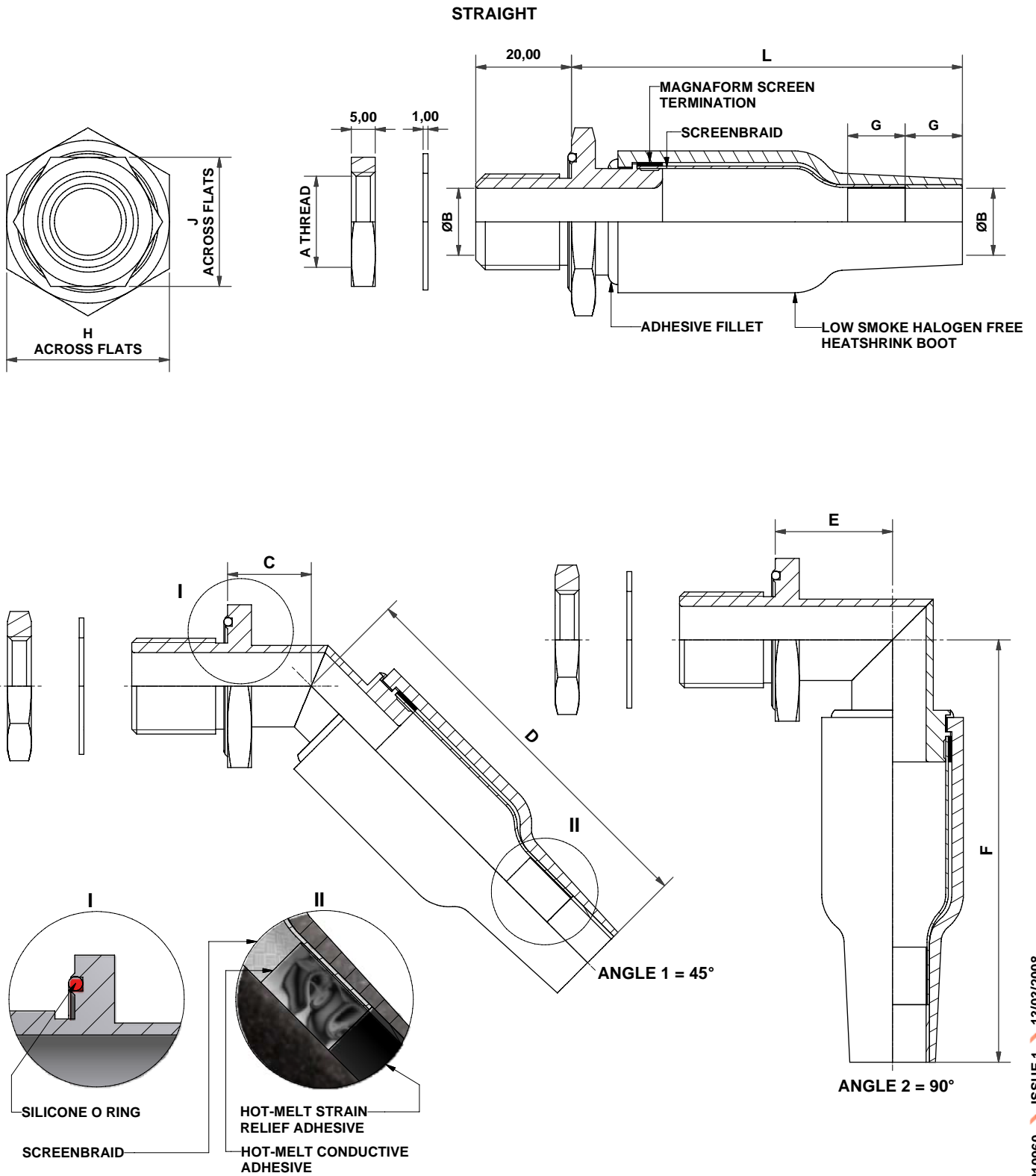

DRAWING NOT TO SCALE  
DIMENSIONS IN MM

NCAGE CODE U5792



# 100P275 SERIES

## HEAT SHRINK GLAND KIT



For modifications see page:

➤ Visit our on-line catalogue or contact sales on ➤ [www.polamco.com](http://www.polamco.com) ➤ [sales@polamco.co.uk](mailto:sales@polamco.co.uk)

<b>EXAMPLE PART NUMBER</b>	100P275	- 20	- 4	- C	- 1	- SB
SERIES						
GLAND SIZE (TABLE 1)						
MATERIAL (TABLE 2)						
PLATING (TABLE 2)						
ANGLE (OMIT FOR STRAIGHT)						
HEATSHRINK TERMINATION (SB – SCREENED BOOT; UB – UNSCREENED BOOT)						

GLAND SIZE	A THREAD	B MIN	C MAX	D MAX	E MAX	F MAX	G +/-2,0	H NOM	J NOM	L MAX	MIN CABLE +/- 0,5
10	M10x1.5	6,2	12,8	77,3	18,6	82,6	10,0	22,0	16,0	80,0	4,5
12	M12x1.5	7,4	14,5	78,5	20,0	83,5	10,0	24,0	17,0	80,0	4,5
16	M16x1.5	10,1	16,5	91,5	21,6	96,6	12,0	29,0	22,0	92,0	5,0
20	M20x1.5	14,1	17,7	92,2	24,6	98,6	12,0	34,0	27,0	92,0	7,0
24	M24x1.5	19,1	19,6	115,6	27,1	124,1	15,0	38,0	30,0	115,0	9,0
30	M30x1.5	24,1	21,6	116,1	31,6	127,6	15,0	48,0	36,0	115,0	10,0
36	M36x1.5	30,1	23,3	146,3	34,6	159,6	20,0	52,0	41,0	145,0	12,5
48	M48x1.5	40,1	-	-	-	-	20,0	67,0	55,0	145,0	15,0

CODE	MATERIAL / PLATING
1-C	ALUMINIUM / ELECTROLESS NICKEL
1-B	ALUMINIUM / CADMIUM OLIVE DRAB OVER ELECTROLESS NICKEL
1-ZB	ALUMINIUM / ZINC COBALT OLIVE DRAB OVER ELECTROLESS NICKEL
4-C	STAINLESS STEEL / ELECTROLESS NICKEL
2-Z	NICKEL ALUMINIUM BRONZE / SHOT BLAST NON REFLECTIVE

LIST NOT EXHAUSTIVE - FOR COMPREHENSIVE LIST AND SPECS SEE WEBSITE

DRAWING NOT TO SCALE  
DIMENSIONS IN MM

NCAGE CODE U5792

