

63 SERIES CONDUIT ADAPTOR

INTERFACE: D

TO FIT TYPICAL CONNECTOR: MIL-DTL-26482 SERIES I, PATT 105, PATT 603, 62GB

For modifications see page:



➤ Visit our on-line catalogue or contact sales on ➤ www.polamco.com ➤ sales@polamco.co.uk

SUITABLE FOR USE WITH 100P2589 SERIES CONDUIT

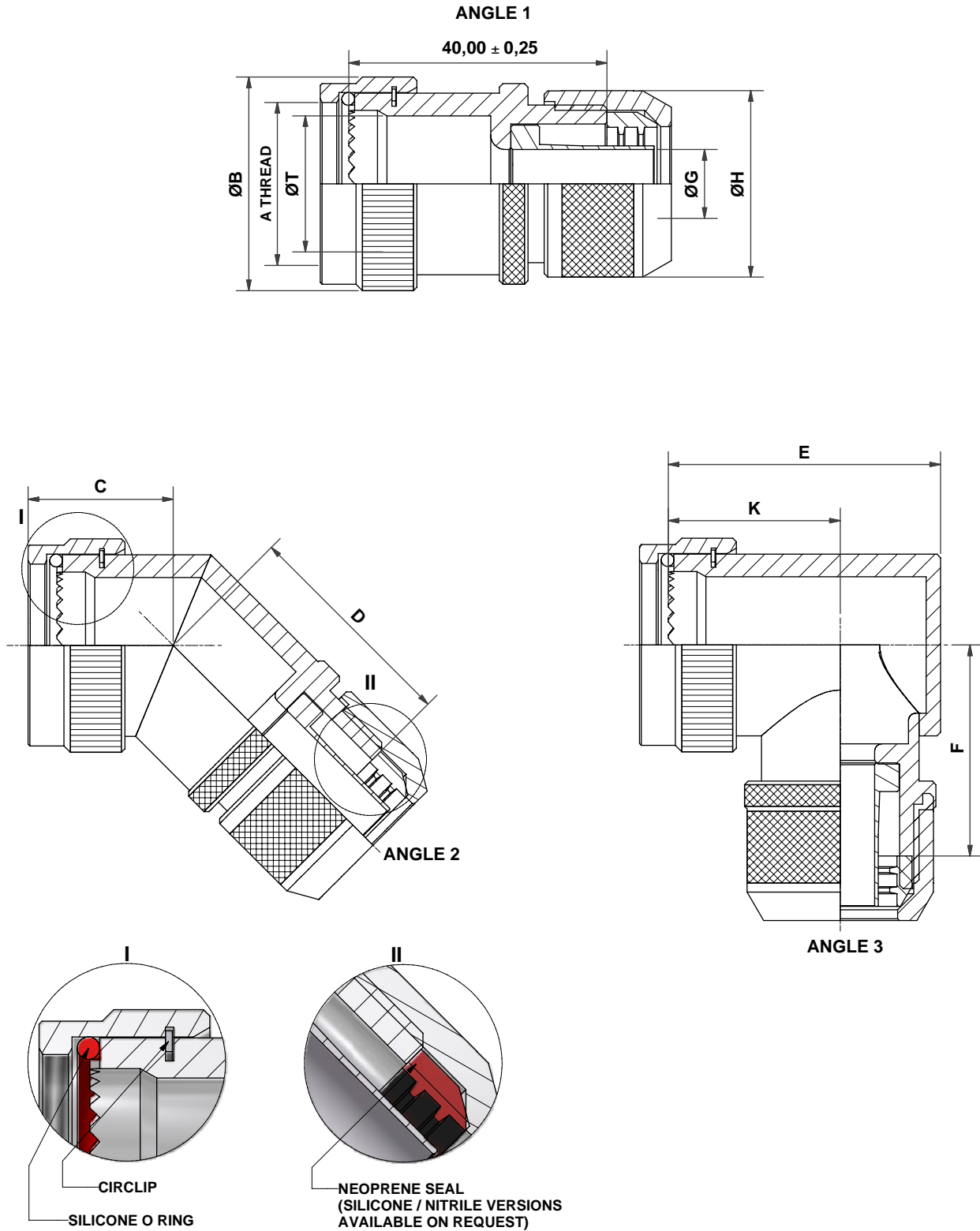

DRAWING NOT TO SCALE
DIMENSIONS IN MM

NCAGE CODE U5792



63 SERIES

CONDUIT ADAPTOR

INTERFACE: D

TO FIT TYPICAL CONNECTOR: MIL-DTL-26482 SERIES I, PATT 105, PATT 603, 62GB

For modifications see page:



➤ Visit our on-line catalogue or contact sales on ➤ www.polamco.com ➤ sales@polamco.co.uk

EXAMPLE PART NUMBER	63	D	1	- 16	- 16	- 1	- C
SERIES							
CONNECTOR INTERFACE							
ANGLE							
SHELL SIZE (TABLE 1)							
CONDUIT SIZE (TABLE 2)							
MATERIAL (1-ALUMINIUM ALLOY)							
PLATING (TABLE 3)							

SHELL SIZE	A THREAD	B MAX	T MIN	C +/- 0,5	D MAX	E MAX	F MAX	K +/- 0,5
08	7/16-28 UNEF	17,3	7,0	14,1	27,2	25,2	35,3	17,5
10	9/16-24 UNEF	20,3	9,6	14,9	28,0	28,2	36,8	18,6
12	11/16-24 UNEF	23,8	13,3	15,3	28,6	31,7	38,3	20,5
14	13/16-20 UNEF	26,8	15,7	16,2	29,6	35,2	39,8	22,5
16	15/16-20 UNEF	29,8	18,8	16,5	30,2	38,2	41,5	24,0
18	1 1/16-18 UNEF	33,3	21,2	17,3	30,9	41,7	43,0	26,0
20	1 3/16-18 UNEF	36,3	24,4	18,2	31,2	45,2	44,7	28,0
22	1 5/16-18 UNEF	39,8	27,6	18,5	31,8	48,2	46,2	29,5
24	1 7/16-18 UNEF	42,8	30,8	19,4	32,5	51,2	47,7	31,0

CONDUIT SIZE	G CABLE MAX	H MAX
13	7,7	23,0
16	9,5	26,0
21	13,4	31,0
28	17,6	38,0
34	22,4	46,0
42	28,6	56,0

CODE	PLATING
B	CADMIUM OLIVE DRAB OVER ELECTROLESS NICKEL
C	ELECTROLESS NICKEL
ZB	ZINC COBALT OLIVE DRAB OVER ELECTROLESS NICKEL

LIST NOT EXHAUSTIVE - FOR COMPREHENSIVE LIST AND SPECS SEE WEBSITE

PART NUMBER (** - SIZE)	DESCRIPTION
100P2589-N6S-**	STANDARD WEIGHT POLYAMIDE (NYLON) 6
100P2589-N11S-**	STANDARD WEIGHT MODIFIED POLYAMIDE 11
100P2589-N11H-**	HEAVYWEIGHT MODIFIED POLYAMIDE 11
100P2589-PS-**	POLYESTER
100P2589-PKS-**	POLYKETONE (PEEK)

DRAWING NOT TO SCALE
DIMENSIONS IN MM

NCAGE CODE U5792

