

# TAK SERIES

## SCREENED TAK ADAPTOR

INTERFACE: F

TO FIT TYPICAL CONNECTOR: MIL-DTL-38999 SERIES I & II

For modifications see page:



➤ Visit our on-line catalogue or contact sales on ➤ [www.polamco.com](http://www.polamco.com) ➤ [sales@polamco.co.uk](mailto:sales@polamco.co.uk)

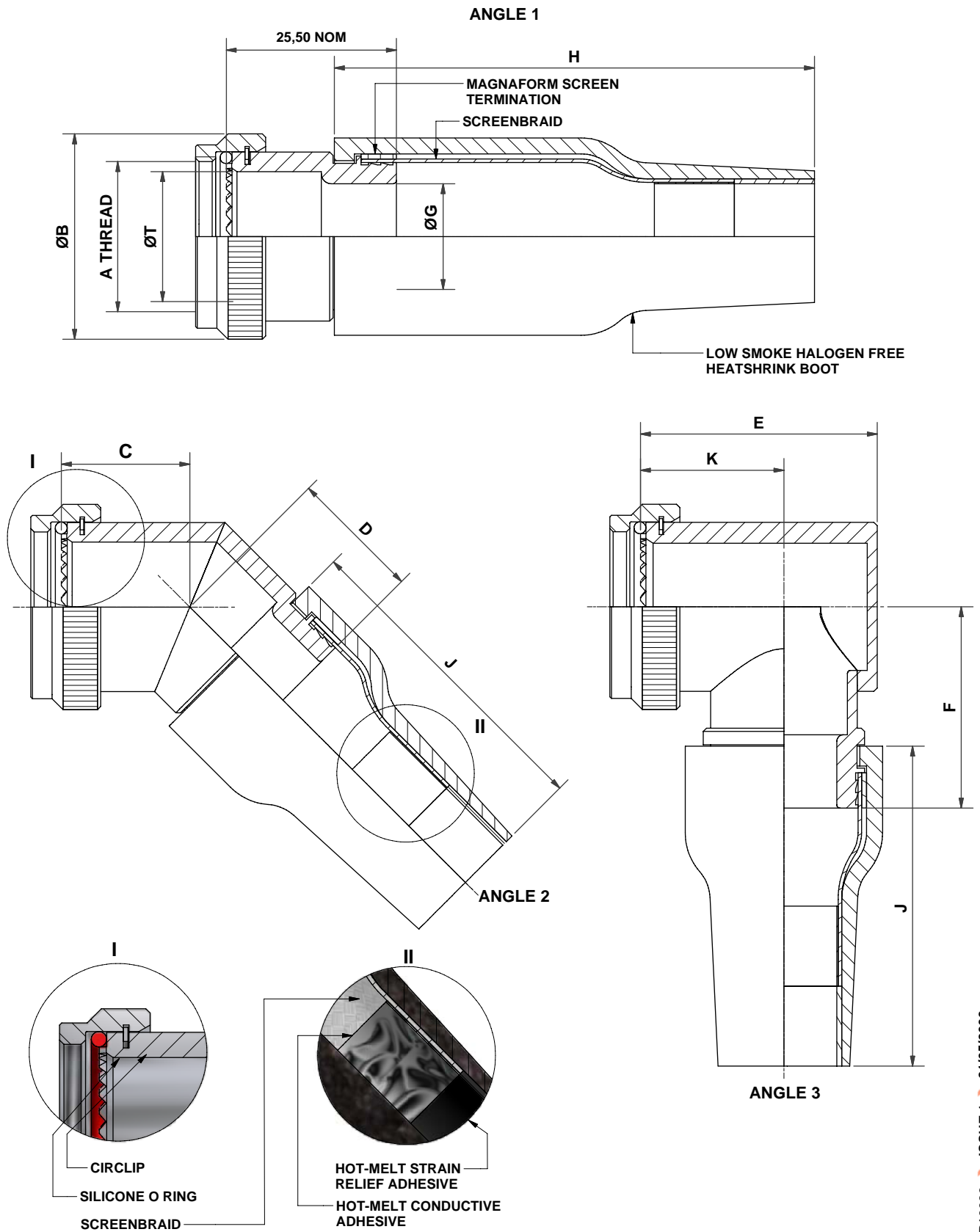

IF THIS DOCUMENT IS PRINTED IT BECOMES UNCONTROLLED. CHECK THE LATEST ISSUE.

NCAGE CODE U5792



# TAK SERIES

## SCREENED TAK ADAPTOR

INTERFACE: F

TO FIT TYPICAL CONNECTOR: MIL-DTL-38999 SERIES I & II

For modifications see page:



➤ Visit our on-line catalogue or contact sales on ➤ [www.polamco.com](http://www.polamco.com) ➤ [sales@polamco.co.uk](mailto:sales@polamco.co.uk)

EXAMPLE PART NUMBER	TAK	F	1	- 16	- 08	- 1	- C	- SB
	SERIES							
	CONNECTOR INTERFACE							
	ANGLE							
	DASH NUMBER (TABLE 1)							
	ENTRY SIZE (TABLE 2)							
	MATERIAL (1-ALUMINIUM ALLOY)							
	PLATING (TABLE 3)							
(SB – SCREENED BOOT; UB – UNSCREENED BOOT)								

DASH NO.	MIL-DTL-38999 SHELL SIZE		A THREAD	B MAX	T MIN	C +/- 0,5	D MAX	E MAX	F MAX	K +/- 0,5
	SERIES I	SERIES II								
08	9	8	7/16-28 UNEF	18,3	6,6	16,6	16,9	22,7	23,3	15,0
10	11	10	9/16-24 UNEF	21,5	10,1	17,4	17,2	26,2	25,0	17,0
12	13	12	11/16-24 UNEF	24,5	12,9	17,8	17,6	29,2	26,5	18,0
14	15	14	13/16-20 UNEF	27,8	16,1	18,7	18,4	32,2	28,1	20,0
16	17	16	15/16-20 UNEF	30,8	19,3	20,4	19,2	35,7	29,7	21,5
18	19	18	1 1/16-18 UNEF	34,1	21,7	19,8	19,5	39,7	30,4	23,0
20	21	20	1 3/16-18 UNEF	37,3	24,9	20,6	20,3	42,2	32,0	25,0
22	23	22	1 5/16-18 UNEF	40,5	28,1	21,0	20,6	45,2	33,6	26,0
24	25	24	1 7/16-18 UNEF	43,7	31,3	21,9	22,0	48,2	35,1	28,0

ENTRY SIZE	G	H LENGTH	J LENGTH	CABLE DIA RANGE
05	7,9	60	40	4,5 – 9,0
08	12,7	60	40	6,0 – 12,0
10	15,8	72	48	7,5 – 15,0
12	19,0	72	48	9,0 – 18,0
16	25,4	95	55	10,0 – 25,0
20	31,8	125	70	12,5 – 30,0
24	38,1	125	70	15,0 – 36,0

CODE	PLATING
B	CADMIUM OLIVE DRAB OVER ELECTROLESS NICKEL
C	ELECTROLESS NICKEL
ZB	ZINC COBALT OLIVE DRAB OVER ELECTROLESS NICKEL

LIST NOT EXHAUSTIVE - FOR COMPREHENSIVE LIST AND SPECS SEE WEBSITE

DRAWING NOT TO SCALE  
DIMENSIONS IN MM

IF THIS DOCUMENT IS PRINTED IT BECOMES UNCONTROLLED. CHECK THE LATEST ISSUE.

NCAGE CODE U5792

