

Suggested Procedure for Cable Termination on Polamco 64 Series

Adaptors

1. Strip off outer insulation to required length.
2. Strip the wire and attached the exposed wire ends to the contacts.

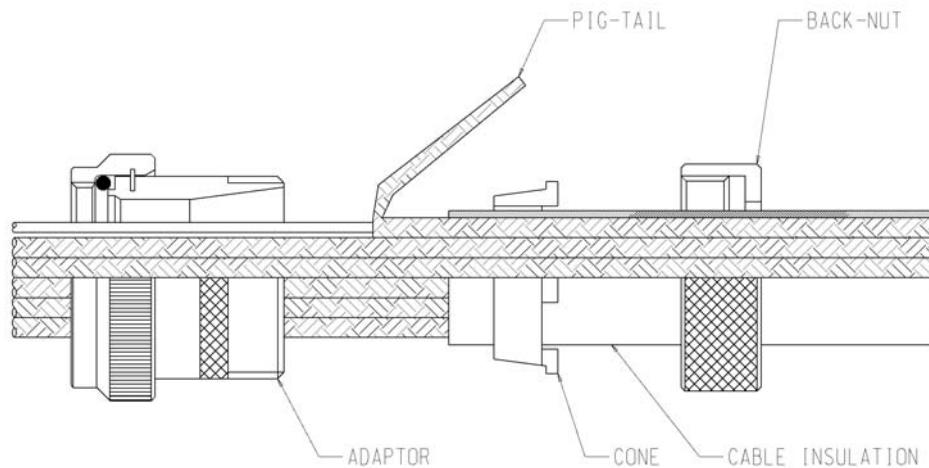

3. Fold back the screen pig-tails and assemble the backshell to the connector ensuring correct engagement of the accessory teeth. Fully tighten the coupling nut by hand
4. Slide the cone along the bundle, trapping the screens, which should be spaced equally around the cone and completely bind the screen tails to the main bundle ensuring total coverage of severed screen ends as shown in Fig. 2. The

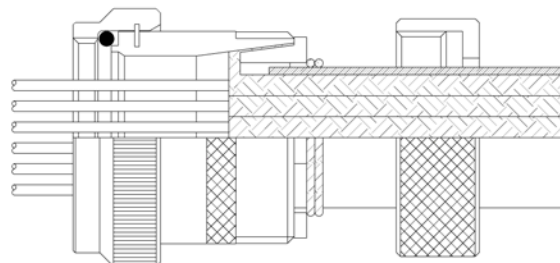

free ends of the screen tails should emerge behind the cone in between the four feet.

5. Fully tighten the backshell by hand.
6. Ensure full tightness of the coupling nut, then, using approved soft-jaw pliers, tighten the back-nut onto the rear of the backshell.
7. Tighten the cable clamp in position (if supplied – not shown below).

