



3RD ANGLE PROJECTION



REMOVE ALL SHARP EDGES AND BURRS

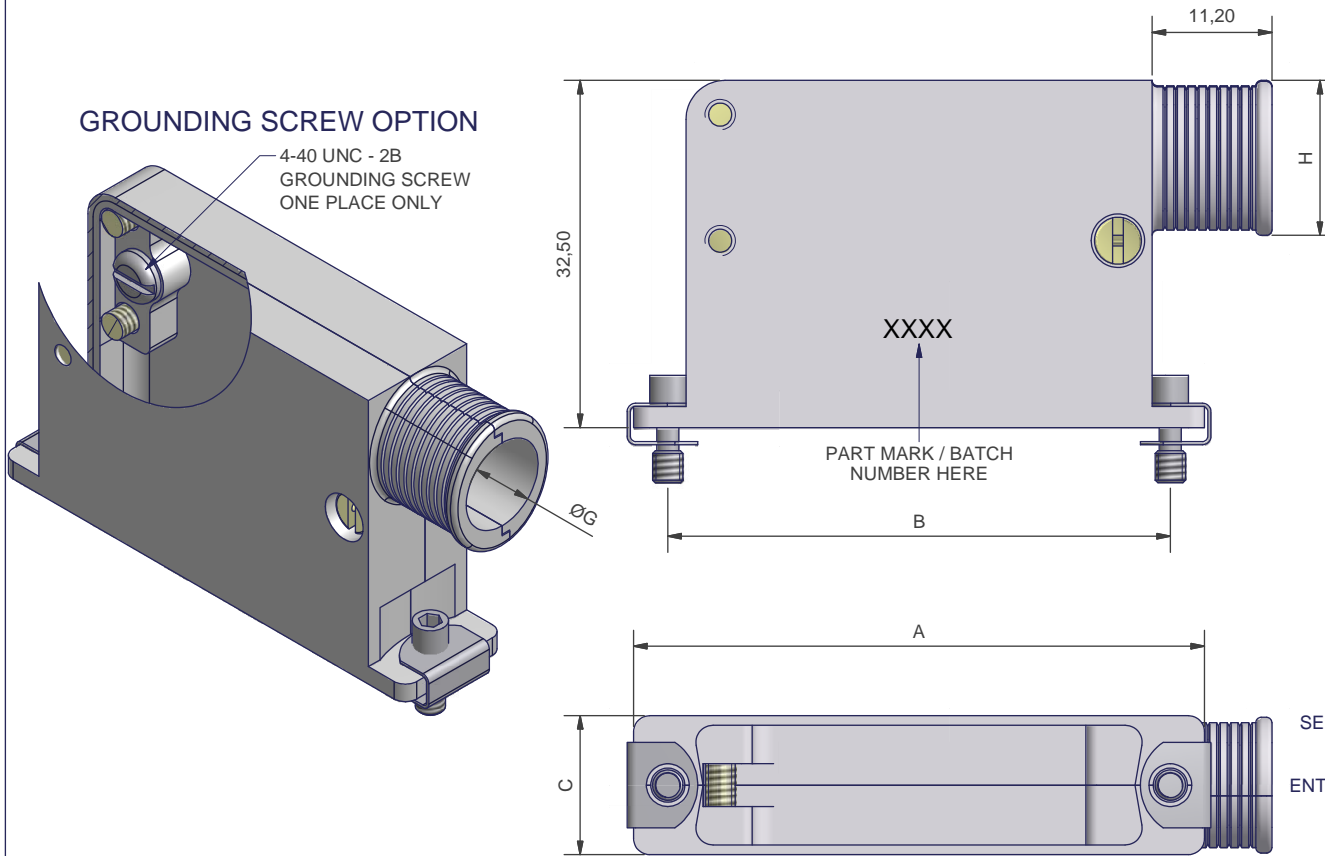

TABLE 1

SHELL SIZE	A	B	C
09	31,0	24,99	13,0
15	39,5	33,32	13,0
25	53,0	47,04	13,0
37	69,5	63,50	13,0
50	66,9	61,11	15,8
104	69,4	63,50	17,4

TABLE 2

ENTRY SIZE	G	H MAX
01	3,18	8,2
02	4,75	9,8
03	6,86	11,9
04	7,37	12,4
05	7,92	12,9
06	9,50	14,5

TABLE 3

CODE	PLATING
B	CADMIUM OLIVE DRAB OVER ELECTROLESS NICKEL
C	ELECTROLESS NICKEL
U	UNPLATED
Y	YELLOW CHROMATE OVER CADMIUM
ZB	ZINC COBALT OLIVE DRAB OVER ELECTROLESS NICKEL

(LIST NOT EXHAUSTIVE - FOR COMPREHENSIVE LIST SEE WEBSITE)

DSF25-R-BTG-06-1-C-SB-H

SERIES (SPLIT D-SUB, FLANGE-MOUNT)
 CONNECTOR SHELL SIZE (TABLE 1)
 ANGLE (R - 90°)
 ENTRY STYLE (BT - BAND TERMINATION)
 G - GROUNDING SCREW OPTION
 (OMIT IF NOT REQUIRED)
 ENTRY SIZE (TABLE 2)
 MATERIAL (1 - ALUMINIUM)
 FINISH (SEE TABLE 3)
 BAND REF.
 (SB - STANDARD BAND (6,1MM X 362MM))
 (MB - MICRO BAND (3,05MM X 207MM))
 (LM - LONG MICRO BAND (3,05MM X 362MM))
 (OMIT FOR NO BAND REQUIRED)
 H - SOCKET HEAD MOUNTING SCREWS
 (OMIT FOR STANDARD SLOTTED HEAD)

ISSUE	DCR NO.	DATE	APPROVED
2	3956	08/09/2010	M.FLAVELL

MATERIAL

SEE ABOVE

UNLESS OTHERWISE SPECIFIED ALL DIMENSIONS IN MILLIMETRES TOLERANCE ON DIMENSIONS +/-0.1MM TOLERANCE ON ANGLES +/- 1 DEGREE

WEIGHT
DRAWN K.SHEPPARD

DO NOT SCALE THIS DRAWING

THIS DRAWING IS COPYRIGHT, AND THE PROPERTY OF POLAMCO LTD. IT MUST NOT BE COPIED, USED FOR MANUFACTURE OR OTHERWISE DISCLOSED WITHOUT PRIOR WRITTEN CONSENT OF THE COMPANY.

POLAMCO LTD

WESTON LOCK
LOWER BRISTOL ROAD
BATH BA2 1EP

TITLE
90° SPLIT D-SUB BANDING ADAPTOR ASSEMBLY

PART NO
DSF25-R-BT-06-1-C-H

ASSY USED ON
MIL-DTL-24308

DRAWING NO
P15583