

96 SERIES STRAIN RELIEF ADAPTOR

INTERFACE: A

TO FIT TYPICAL CONNECTOR: MIL-C-26482 SERIES II, MIL-C-83723 SERIES III

For modifications see page:



➤ Visit our on-line catalogue or contact sales on ➤ www.polamco.com ➤ sales@polamco.co.uk

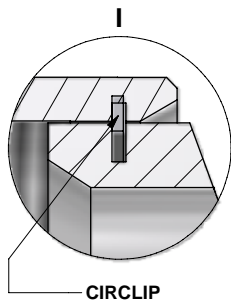
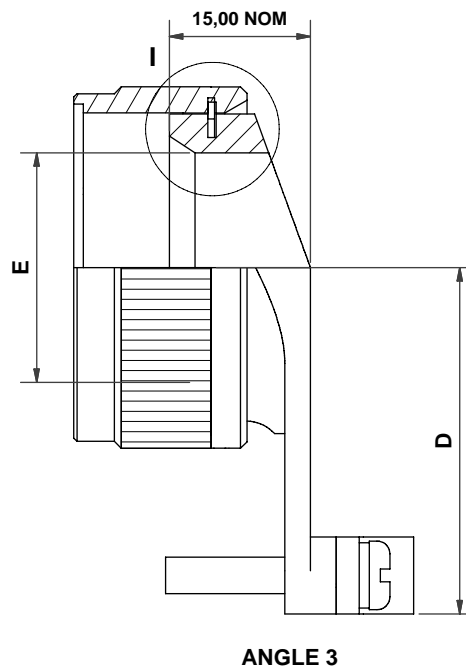
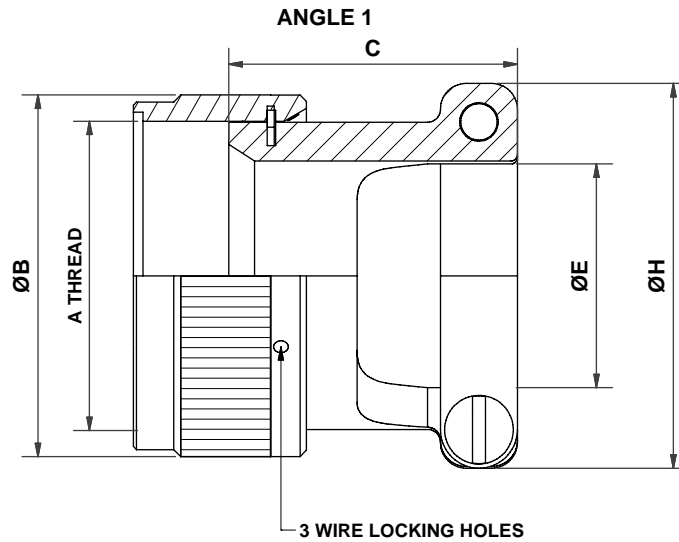

DRAWING NOT TO SCALE
DIMENSIONS IN MM

NCAGE CODE U5792



96 SERIES

STRAIN RELIEF ADAPTOR

INTERFACE: A

TO FIT TYPICAL CONNECTOR: MIL-C-26482 SERIES II, MIL-C-83723 SERIES III

For modifications see page:



➤ Visit our on-line catalogue or contact sales on ➤ www.polamco.com ➤ sales@polamco.co.uk

EXAMPLE PART NUMBER	96	A	1	- 16	- 1	- C
SERIES						
CONNECTOR INTERFACE						
ANGLE						
SHELL SIZE (TABLE 1)						
MATERIAL (1-ALUMINIUM ALLOY)						
PLATING (TABLE 3)						

SHELL SIZE	A THREAD	B MAX	C MAX	E MIN	H MAX	D +/- 0,2
03	9/16-24 UNEF	17,0	21,2	6,6	19,0	20,5
08	1/2-20 UNF	15,6	21,2	6,6	19,0	20,5
10	5/8-24 UNEF	18,6	21,2	9,3	20,6	22,0
12	3/4-20 UNEF	21,7	22,2	12,7	25,2	23,0
14	7/8-20 UNEF	24,9	22,2	14,6	26,9	25,4
16	1-20 UNEF	28,2	22,5	17,8	30,2	27,0
18	1 1/16-18 UNEF	30,9	26,5	19,8	33,2	28,6
20	1 3/16-18 UNEF	34,1	30,0	23,0	38,0	32,0
22	1 5/16-18 UNEF	37,3	36,0	26,1	41,2	33,0
24	1 7/16-18 UNEF	40,4	36,0	29,1	44,4	36,5

CODE	PLATING
B	CADMIUM OLIVE DRAB OVER ELECTROLESS NICKEL
C	ELECTROLESS NICKEL
ZB	ZINC COBALT OLIVE DRAB OVER ELECTROLESS NICKEL

LIST NOT EXHAUSTIVE - FOR COMPREHENSIVE LIST AND SPECS SEE WEBSITE

DRAWING NOT TO SCALE
DIMENSIONS IN MM

NCAGE CODE U5792

